



CANTER

CANTER 515 ALLOY TRAY

4X2 / WIDE CAB / DUONIC OR MANUAL



OUR SAFEST CANTER EVER WITH AEB, LDWS AND ESP STANDARD.

CLASS LEADING 30,000KM SERVICE INTERVALS.

ALLOY TRAY WITH TWO-PIECE DROP SIDES AND REMOVABLE MIDDLE AND REAR RACK.

GVM

4,495_{KG}

GCM

7,995_{KG}

Power/Torque

110_{kW} / 370_{Nm}

- Can be driven on a passenger car licence
- Actual product may vary from image shown.

CANTER SPECIFICATIONS

MODEL

A	4X2 515 BUILT READY WIDE CAB ALLOY TRAY 6 SP. DUONIC AMT FEB21ER3SFBLE02/E04
B	4X2 515 BUILT READY WIDE CAB ALLOY TRAY MWB 5 SP. MANUAL FEB21ER4SFBG-E02/E04

WHEEL BASE

3400mm
3400mm

GVM (optional)

4,495kg
4,495kg

GCM (optional)

7,995kg
7,995kg

Engine

Engine Version	FUSO 4P10-T4 Diesel
Configuration	4 Cyl. In-line DOHC, 4-Valve
Injection System	Bosch Common Rail Direct Injection Bosch Piezo Technology Injectors
Type	Variable Geometry Turbo Charged Air to Air Intercooled
Displacement	3 litre (2998cc)
Bore	95.8mm
Stroke	104mm
Power (DIN)	110kW @ 2840~3500 rpm
Torque (DIN)	370Nm @ 1350~2840 rpm
Maximum Engine Speed	4100 rpm
Compression Ratio	17.5:1
Cooling System / Oil Cooler	Water cooled, 13.7L capacity/ Plate type engine oil cooler
Air Cleaner	Paper Element Type with Restrictor Indicator. Vertical Intake Mounted on Clean Air Side (RH)
Emission Control	Diesel Particulate Filter (DPF) Exhaust Dash Display DPF Status 0~9 (Empty~Full) Parked Regeneration possible from 7~9
Emission Level	ADR 80/03 - Euro 5

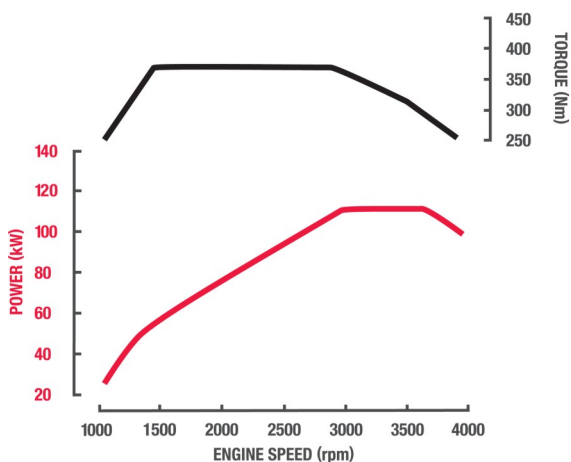

Fuel

Tank Type	Rectangular Steel Tank with Locking Cap
Fuel Capacity *	100 Litres
Filtration	Filter with Water Separator and Indicator Sensor
Notes	*Max Fill to approx 95% of capacity

Cooling

Fan Drive	Thermo modulated continuous control (Viscous)
Radiator	Corrugated Fin with Expansion Tank

Electrical

Voltage	12V Negative Earth
Battery Capacity	2x12V, 70Ah/5hr
Battery Specification	115D31L x2
Headlamp Type	LED
Body Builder Harness	Yes

Clutch

Clutch Model	A Duonic Automated Manual (no clutch pedal)	B FUSO C4W30
Type	A Dual Clutch (Wet Multi-plate)	B Single Dry Plate, Direct Hydraulic Type

Transmission

Version	A FUSO DUONIC M038S6	B FUSO M038S5
Type/Speeds	A 6 Speed Dual Clutch with Auto and Manual Modes	B 5 Speed with In-Dash Gearshift Lever
Features	A Virtually Instant Gear Changes In-Dash Gear Lever with Park Brake Position ECO Mode to Minimise Fuel Usage	B Synchronesh 1st-5th
Ratios	A 1st: 5.397 2nd: 3.788 3rd: 2.310 4th: 1.474 5th: 1.000 6th: 0.701 Rev. 5.397	B 1st: 5.494 2nd: 3.038 3rd: 1.592 4th: 1.000 5th: 0.723 Rev. 5.494
PTO Opening	LH Side	

Front Axle

Axle Version	FUSO F200T
Type	Independent Front Suspension
Capacity *	2300kg
Notes	*See MAX LOADING for vehicle capacity.

Front Suspension

Type	Double Wishbone Independent Front Suspension with Coil Springs and Shock Absorbers
------	--

Rear Axle

Type	Full Floating Banjo Type
Axle Version	FUSO R030T
Capacity*	3800kg
Ratio	4.444:1
Notes	*See MAX LOADING for vehicle capacity.

Rear Suspension

Type	Steel Suspension
Details	Parabolic Leaf with Shock Absorbers
Size Main Leaves	1100x70mm

Max Loading

Front	2180kg
Rear	3800kg
Total	4495kg

Options

Options	E02 - Std E04 - Ladder racks
---------	---------------------------------

Steering

Type	Rack & Pinion
Steering Column	Tilt/Telescopic Adjustable
Power Assist	Standard

CANTER SPECIFICATIONS

MODEL

A	4X2 515 BUILT READY WIDE CAB ALLOY TRAY 6 SP. DUONIC AMT FEB21ER3SFBL-E02/E04
B	4X2 515 BUILT READY WIDE CAB ALLOY TRAY MWB 5 SP. MANUAL FEB21ER4SFBG-E02/E04

WHEEL BASE

3400mm
3400mm

GVM (optional)

4,495kg
4,495kg

GCM (optional)

7,995kg
7,995kg

Brakes

Type	Hydraulic Dual Circuit with Front and Rear Discs
Size Front	219x28mm
Size Rear	219x28mm
Features	ABS plus EBD (Electronic Brake Distribution) Active Emergency Braking System (AEBS) Electronic Stability Program (ESP) Exhaust Brake Electronic Brake Wear Sensors
Park Brake	Transmission Mounted

Wheels & Tyres

Wheel Type	7 x Single Piece Disc Rims (Including Spare)
Wheel Size	16.0x5.5K-115
Wheel Stud Pattern	5 Stud 208 PCD
Tyre Size All	185/85R16 111/109
Spare Tyre Carrier	Provided

Chassis

Type	Reinforced Tapered Channel
Size	188x60x4mm
Width	748mm
Tensile Strength	540 MPa

Instruments

Gauges	Speedometer with Odometer Tachometer Fuel Level Water Temperature
Colour Information Display	Fuel Consumption DPF Bar Chart from 1~9 Water Temperature Lane Departure Warning Maintenance Reminder System Tripmeters

Multi-Media Package

Satellite Navigation	GPS navigation specifically designed for commercial vehicle applications, with 3 years of Map updates included.
Colour Display	8" LCD with capacitive touch screen control
Phone Connectivity	Wireless Apple Carplay & Android Auto Compatible
Audio Visual Entertainment	Bluetooth® music streaming compatible Digital radio DAB+ (also AM/FM for areas not covered by DAB+) & USB
Camera Compatibility	1 Reverse Camera fitted as standard Display can accept up to 5 additional cameras#
Notes	# Cameras available through spare parts

Standard Features

Airbag(s)	Dual Air Bags and Seat Belt Pre-Tensioners (Driver & Far Side Passenger)
Active Safety Features	ABS plus Electronic Brake force Distribution (EBD) Advanced Emergency Braking (AEBS) Anti-Slip Regulator (ASR) Electronic Stability Program (ESP) Lane Departure Warning System (LDWS)
Cruise Control	A Yes B No
Hill Start System	A Yes B No
Cab Cooling & Heating	Air Conditioner / Heater / Demister
Accessory Power	12V Accessory Power Outlet / Cigar Lighter
Driving	Fuso Multimedia Unit Keyless Central Locking Electric Windows Cup Holders 2 3 seats
Storage	Dual Overhead Storage Pockets In-Dash Centre Document Storage Door Storage Pockets Dash Storage Tray (1 DIN) Coat Hooks
Cab: External	Front End-Outline Marker Lamps Door Side Impact Beams
Chassis	Reverse Warning Buzzer Factory Reverse Camera with Infrared Display and Audible Pickup (Supply only in Cabin)

Cab Features

Type	All Steel Forward Control Manual Tilt
Cab Structure	ECE-R29 European Cab Strength Approved
Mounting	Hydroelastic 4 Point
Additional Engine Access	A Removable Engine Access Panel B N/A
Colour	Natural White
Windscreen Wipers	2 Speed + Intermittent Cycle with Integrated Washer Nozzles
Rear Vision Mirrors	1 x Internal 2 x External Convex (ECE 46) - Heated
Seating Capacity	3
Seat Belts	Lap Sash Belts for Outside Seating Positions Lap Belt for Centre Seat Driver Seat Belt Warning
Seat (driver)	Suspended with Weight Adjustment, LH Arm Rest and Lumbar Support
Seats (passenger)	Flat Folding, 2 Passenger Bench

Service Intervals

Interval*	30,000km or 12 Months (whichever occurs first)
Notes*	* For full details please refer to the Vehicle's Owner's Manual.

Warranty*

Basic/Powertrain	5 Years or 200,000kms (whichever occurs first)
Cab Perforation/Anti Corrosion	5 Years
Body	5 Years or 200,000kms (whichever occurs first)
Notes	* Please refer to Fuso Owners Warranty Booklet for additional terms and conditions.

CANTER SPECIFICATIONS

MODEL

- A 4X2 515 BUILT READY WIDE CAB ALLOY TRAY 6 SP. DUONIC AMT FEB21ER3SFBL-E02/E04
- B 4X2 515 BUILT READY WIDE CAB ALLOY TRAY MWB 5 SP. MANUAL FEB21ER4SFBG-E02/E04

WHEEL BASE

3400mm
3400mm

GVM (optional)

4,495kg
4,495kg

GCM (optional)

7,995kg
7,995kg

Performance

Turning Circle (kerb to kerb - metres)	11.0	
Road Speed (km/h) at Max Engine Speed	A 136	B 137
Engine Speed (rpm) at 100km/hr (top gear)	A 2346	B 2420
Gradeability at Rated GVM (theoretical)*	A 45.5%	B 46.5%
Notes	*This is theoretical performance only. Actual performance may vary under different conditions	

Mass estimated*

Front*	A 1525kg	B 1505kg
Rear*	825kg	
Total*	A 2350kg	B 2330kg
Notes	* Mass (est.) includes oil and water but excludes spare wheel, tools & fuel. Weights provided are subject to 3.5% variation (+/-)	

Dimensions mm

WFF (Width Front Fender) (mm)	1995
WRA (Width Rear Axle) (mm)	1929
WFT (Width Front Track) (mm)	1655
WRT (Width Rear Track) (mm)	1495
Width Frame (mm)	748
MAX. RECOMMENDED BODY WIDTH (mm)	(304)
A - Length Overall (mm)	6255
C - Front Overhang (mm)	1140
D - Wheelbase (mm)	3400
N - Height Overall (mm)	2290
OT - Outside tray (mm)	2122
IT - Inside Tray (mm)	2057
LT - Length Tray (mm)	4500
HT - Height Tray (mm)	330
TG - Tray to Ground (mm)	935
RO - Rear Overhang (mm)	1715

Body Builder's Notes

Notes	N/A
-------	-----

Built Ready

Features	<ul style="list-style-type: none"> • 3 Tonne Rated Slat Aluminum Floor* • Front Steps with Non-Slip Tread • Continues Rope Rail with Plugs • Tube Headboard with Mesh Infill And Grab Handles
Optional Features	E04 - Ladder racks
Length (mm)	4525
Width (mm)	2122
Height (mm)	330
Overall Unit Length (mm)	6255
Notes	* See MAX LOADING for vehicle capabilities

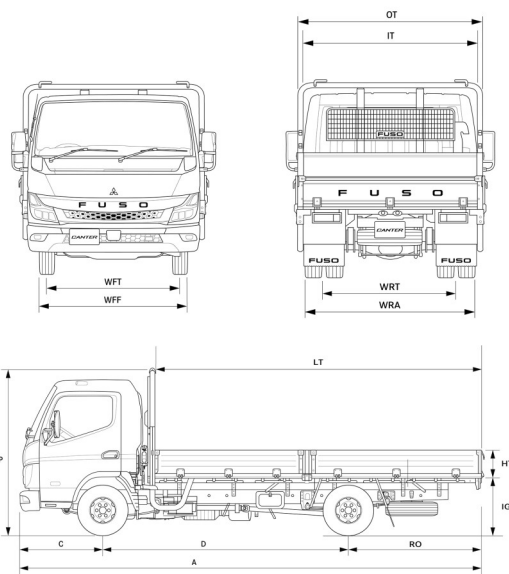

Call 1800 033 557

or visit fuso.com.au

Unless specified in writing herein the accessories, applications, bodies or equipment depicted in this are for illustration purposes only and may not be available from Daimler Truck Australia Pacific Pty Ltd. ABN 86 618 413 282 DTAuP. DTAuP reserves the right without notice or obligation to discontinue or make changes to the colour, designs, materials and specifications of the products and options referred to herein at any time. For the most current information and in order to ascertain which accessories, applications, bodies and equipment are available from DTAuP please contact your authorised FUSO dealer. Fuso is a registered trademark of Daimler Truck Australia Pacific Pty Ltd. Copyright DTAuP. Reproduction in whole or part prohibited without written approval. Valid from 02-Apr-24.