

FUSO SHOGUN

Shogun FV70 6X4

AMT / MECH SUSP. / MWB



ADVANCED EMERGENCY BRAKING, LANE DEPARTURE WARNING AND ACTIVE ATTENTION ASSIST AS STANDARD.

GVM

25,400_{KG}

GCM

53,000_{KG}

Power/Torque

290_{KW} / 2000_{NM} -

335_{KW} / 2200_{NM}

- Heavy rigid licence required

SHOGUN SPECIFICATIONS

MODEL

A	6X4 FV70 395HP MWB 12 SP. AMT (FV70HK2VFAA)
B	6X4 FV70 455HP MWB 12 SP. AMT (FV70HK4VFAA)

WHEEL BASE

4300mm
4300mm

GVM

25,400kg
25,400kg

GCM

53,000kg
53,000kg

Engine

Engine Version	A FUSO OM470-T2 Diesel	B FUSO OM470-T4 Diesel
Configuration	6 Cyl. In-line OHV	
Injection System	Common Rail Direct Injection with Pressure Booster	
Type	Asymmetric Turbocharger, Air to Air Intercooler	
Displacement	10.7 litre (10677 cc)	
Bore	125 mm	
Stroke	145 mm	
Power (DIN)	A 290 kW (395 hp) @ 1600 rpm	B 335 kW (455 hp) @ 1600 rpm
Torque (DIN)	A 2000 Nm (1475 lb.ft) @ 1100 rpm	B 2200 Nm (1622 lb.ft) @ 1100 rpm
Maximum Engine Speed	2100 rpm	
Compression Ratio	18.5:1	
Air Cleaner	Paper Element Type with Restrictor Indicator. Vertical Intake Mounted on Clean Air Side (RH)	
Emission Control	Diesel Particulate Filter (DPF) plus SCR After-Treatment System	
Emission Level	ADR 80/04 - Euro VI	

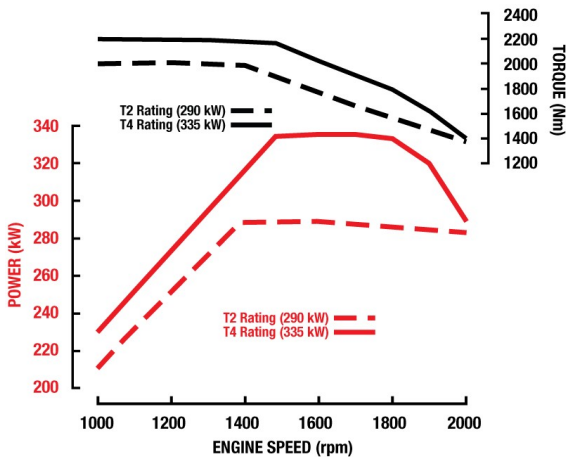

Fuel

Tank Type	Rectangular Aluminium Tank with Locking Cap
Fuel Capacity *	400 Litres
Filtration	Filter with Water Separator and Dash Indicator
AdBlue Exhaust Fluid Capacity	60 Litres, Tank fitted with locking AdBlue cap
Speed Limiter	Speed Limited 100km/h
Notes	*Max Fill to approx 95% of capacity

Cooling

Fan Drive	Electronically controlled (Viscous)
Radiator	Corrugated Fin with Expansion Tank

Electrical

Voltage	24V Negative Ground
Battery Capacity	2x12V, 150Ah/20hr
Battery Specification	2x145G51 (N150)
Headlamp Type	Automatic Type Low Beam: LED High Beam: Halogen
Daytime Running Lamps	Standard
Notes	*Unless Option Q02 is selected

Clutch

Clutch Model	FUSO K4/430
Type	Single Dry Plate
Operation/Specification	Automated Manual (no clutch pedal)

Transmission

Version	FUSO Automated Manual G230-12
Type/Speeds	12 Speed Automated Manual with Auto, Economy and Manual Modes
Features	Crawler Mode Skip Shift Function for Light Loads ECO Mode to Minimise Fuel Usage
Ratios	1st: 11.672 2nd: 9.101 3rd: 7.055 4th: 5.501 5th: 4.400 6th: 3.430 7th: 2.652 8th: 2.068 9th: 1.603 10th: 1.250 11th: 1.000 12th: 0.779 RHigh: 9.101 RLow: 11.672 Torque limited from 1st to 3rd and Reverse
PTO Opening	Rear of Transmission

Propeller Shaft

Type	Single Main Shaft GW5E2200 Inter-axle Shaft P12
------	--

Front Axle

Axle Version	FUSO F900T
Type	Reverse Elliot 'I' Beam
Capacity *	7100kg
Notes	*See MAX LOADING for vehicle capacity.

Front Suspension

Type	Long Taper Leaf with Stabiliser Bar and Double Acting Shock Absorbers
Size	1500x90mm Leaves

Rear Axle

Type	Full Floating Hypoid Type Tandem Drive with Inter-Axle Diff Lock Limited Slip Differential (LSD) to both Axles
Axle Version	FUSO R10TT/R10T
Capacity*	21600kg
Ratio	4.625:1
Notes	*See MAX LOADING for vehicle capacities

Rear Suspension

Type	Mechanical Suspension
Details	Long Leaf Taper, 6 Rod Trunnion
Size Main Leaves	1320x90mm

Max Loading

Front	6500kg
Rear	21600kg
Total	25400kg

Options

Options	Q02: Engine Flywheel PTO (650 Nm) 24V-150A Alternator Bridgestone Tyres
---------	---

SHOGUN SPECIFICATIONS

MODEL

A	6X4 FV70 395HP MWB 12 SP. AMT (FV70HK2VFAA)
B	6X4 FV70 455HP MWB 12 SP. AMT (FV70HK4VFAA)

WHEEL BASE

4300mm
4300mm

GVM

25,400kg
25,400kg

GCM

53,000kg
53,000kg

Steering

Type	Integral Ball and Nut
Steering Column	Tilt/Telescopic Adjustable

Brakes

Type	Full Air, Dual Circuit with FUSO Taper Rollers
Size Front	410x160mm
Size Rear	410x200mm
Features	Exhaust Brake Brake Priority System
Park Brake	Rear Wheel Spring Actuated
Engine	Constant Throttle Brake 3 Levels of Retardation
Trailer	Hand Control Valve, Air Lines Coupling and Electrical Cable

Wheels & Tyres

Wheel Type	10, Single Piece Alloy Disc
Wheel Size	22.5x8.25
Wheel Stud Pattern	10x335mm PCD
Tyre Brand	Michelin*
Tyre Size Front	295/80R22.5 152/148
Tyre Size Rear	11R22.5 148/145
Notes	*Unless Option Q02 is selected

Chassis

Type	Reinforced Parallel Channel
Size	300x90x7.0 mm
Width	840 mm
Tensile Strength	540 MPa

Instruments

Gauges	Speedometer Tachometer Fuel Level Air Pressure AdBlue Level
Colour Information Display	Odometer Tripmeter (x2) Hour Meter (x2) Outside Temperature AdBlue Level DPF Information Driving Range (Fuel and AdBlue) Current Vehicle Speed Cruise Control Lane Departure Warning Active Attention Assist Warning Alarm Clock Service Indicator & Reminder System Air Pressure Coolant Temperature Engine Oil Level & Running Time
Warning Lamps	ABS ASR ESP ESP Off Turn Signal Headlamps High Beam Hill Holder Auxiliary Brake Parking Brake Engine Over-speed Air Pressure Low Cab Tilt Lock DPF Regeneration DPF Status AdBlue Empty AdBlue Contamination Active Brake Assist
Warning Lamp/Buzzer	Air Pressure Cab Tilt Engine Over-speed AdBlue Empty AdBlue Contamination

Multi-Media Package

Satellite Navigation	GPS navigation specifically designed for commercial vehicle applications, with 3 years of Map updates included.
Colour Display	7 inch LCD with touch screen control
Phone Connectivity	Bluetooth® hands free
Audio Visual Entertainment	Bluetooth® music streaming compatible Digital radio DAB+ (also AM/FM for areas not covered by DAB+) & USB
Camera Compatibility	Reverse camera (Factory Fitted) + 5 additional camera options #
Notes	# Cameras available through spare parts

SHOGUN SPECIFICATIONS

	MODEL	WHEEL BASE	GVM	GCM
A	6X4 FV70 395HP MWB 12 SP. AMT (FV70HK2VFAA)	4300mm	25,400kg	53,000kg
B	6X4 FV70 455HP MWB 12 SP. AMT (FV70HK4VFAA)	4300mm	25,400kg	53,000kg

Standard Features

Airbag(s)	Driver's Air Bag and Seat Belt Pre-tensioners
Active Safety Features	ABS plus EBD (Electronic Brake force Distribution) EBS Active Attention Assist Advanced Emergency Braking (AEBS/ABA4) Adaptive Cruise Control (with Stop & Go) Anti-Slip Regulator (ASR) Electronic Stability Program (ESP) Lane Departure Warning System (LDWS)
Hill Start System	Yes
Cab Cooling & Heating	Climate Control
Accessory Power	24V Accessory Power Outlet (x2) plus Cigar Lighter
Driving	Suspended Driver's Seat Central Locking Electric Windows LH Transom Window Opening Rear Quarter Glass Cup Holder Fluorescent Cabin Lamp
Storage	Centre Storage Compartments (x3 Total, Lockable x1) Driver's Overhead Storage Door Storage Pockets Coat Hooks
Cab: External	Fog Lights Door Side Impact Beams Roof Mounting Points max. static load 70kg Front End-Outline Marker Lamps External PTO controls
Chassis	Integrated Front Underrun System (FUPS) Reverse Warning Buzzer Clear Top of Chassis Rail for ease of Body Fitment

Service Intervals

Interval*	50,000km or 12 Months (whichever occurs first)
-----------	--

Warranty*

Basic/Powertrain	5 Years or 500,000kms (whichever occurs first)
Cab Perforation/Anti Corrosion	5 Years
Notes	* Please refer to Fuso Owners Warranty Booklet for additional terms and conditions.

Performance

Turning Circle (kerb to kerb - metres)	15.2
Electronically Speed Limited to:	100km/hr Conforms to ADR65/00
Engine Speed (rpm) at 100km/hr (top gear)	1879
Gradeability at Rated GVM (theoretical)*	A 61% B 66%
Gradeability at Rated GCM (theoretical)*	28%
Notes	*This is theoretical performance only. Actual performance may vary under different conditions

Mass estimated*

Front*	A 4300kg B 4340kg
Rear*	A 3345kg B 3335kg
Total*	A 7645kg B 7675kg
Notes	* Mass (est.) includes oil and water but excludes spare wheel, tools & fuel. Weights provided are subject to 3.5% variation (+/-)

Dimensions mm

WFF (Width Front Fender) (mm)	2490
WRA (Width Rear Axle) (mm)	2480
WFT (Width Front Track) (mm)	2075
WRT (Width Rear Track) (mm)	1865
Width Frame (mm)	840
A - Length Overall (mm)	7640
B - Extreme Axle Spacing (mm)	4960
C - Front Overhang (mm)	1370
D - Wheelbase (mm)	4300
F - Rear Axle Spacing (mm)	1320
G - Front Axle to Rear of Cab (mm)	700
H - Rear of Cab to Rearmost Item Behind Cab (mm)	145
I - Rearmost Item Behind Cab to Rear Axle (mm)	3455
J - Frame, Rear Axle to End (mm)	1970
N - Height Overall (mm)	A 3180 B 3300
O - Air Intake to Cab Roof (mm)	205
P - Height Cab to Ground (mm)	A 2975 B 3095
Q - Height Cab to Frame (mm)	A 1970 B 2090
R - Height Rear Frame to Ground (mm)	1058

Body Builder's Notes

Notes	Chassis reinforcement must be utilised for Tipper/ Demountable type body configurations. To conform with ADR 13/00 (lighting requirements) the following must be adhered to at body installation. - If other than a flat type or tipper body is fitted, rear end out-line marker lamps must be installed. - If overall length exceeds 6.0 metres, side reflectors must be installed. - If overall length exceeds 7.5 metres, side marker lamps must be installed. To conform with ADR 42/04 (General Safety), rear wheel guards must be fitted to the vehicle.
-------	---

SHOGUN SPECIFICATIONS

MODEL	WHEEL BASE	GVM	GCM
A 6X4 FV70 395HP MWB 12 SP. AMT (FV70HK2VF4AA)	4300mm	25,400kg	53,000kg
B 6X4 FV70 455HP MWB 12 SP. AMT (FV70HK4VF4AA)	4300mm	25,400kg	53,000kg

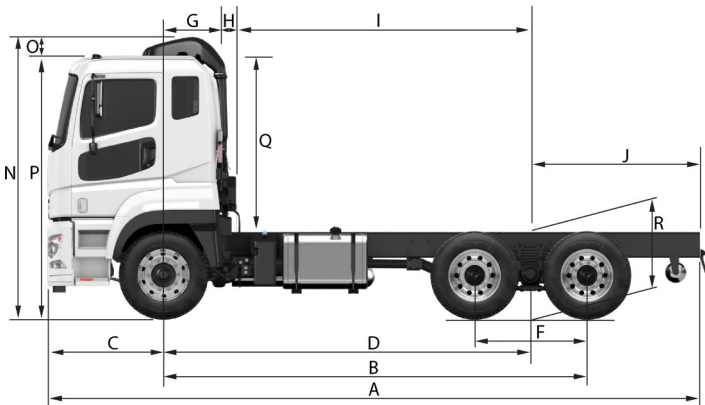
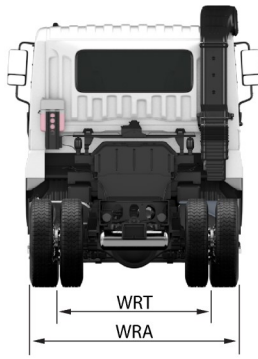

Call 1800 033 557

or visit fuso.com.au

Unless specified in writing herein the accessories, applications, bodies or equipment depicted in this are for illustration purposes only and may not be available from Daimler Truck Australia Pacific Pty Ltd. ABN 86 618 413 282 DTAuP. No representation or warranty whatsoever is given in relation to any accessories, applications, bodies or equipment or suitability of same that are shown herein that may be manufactured, supplied or fitted by a party other than DTAuP. DTAuP reserves the right without notice or obligation to discontinue or make changes to the colour, designs, materials and specifications of the products and options referred to herein at any time. For the most current information and in order to ascertain which accessories, applications, bodies and equipment are available from DTAuP please contact your authorised FUSO dealer. Fuso is a registered trademark of Daimler Truck Australia Pacific Pty Ltd. Copyright DTAuP. Reproduction in whole or part prohibited without written approval. Part Number TSS22A-SSV3. Valid from 17-May-21.