

# FUSO CANTER

## CANTER FG 4x4

WIDE CAB / MANUAL HIGH/LOW RANGE



**CLASS LEADING TARE WEIGHT AND 30,000KM SERVICE INTERVALS**

**GVM**

**6,500<sub>KG</sub>**

**GCM**

**10,000<sub>KG</sub>**

**Power/Torque**

**110<sub>KW</sub> / 370<sub>NM</sub>**

- Light rigid licence required.
- Can be derated and driven with a passenger car licence.

# CANTER SPECIFICATIONS

## MODEL

A	4X4 FG WIDE CAB SWB 5 SP. MAN (FGB71CR6SFBC)
B	4X4 FG WIDE CAB MWB 5 SP. MAN (FGB71ER6SFBC)

## WHEEL BASE

2815mm
3415mm

## GVM (optional)

6,500kg (4,495kg)
6,500kg (4,495kg)

## GCM (optional)

10,000kg (7,995kg)
10,000kg (7,995kg)

Engine	
Engine Version	FUSO 4P10-T4 Diesel
Configuration	4 Cyl. In-line DOHC, 4-Valve
Injection System	Bosch Common Rail Direct Injection Bosch Piezo Technology Injectors
Type	Variable Geometry Turbo Charged Air to Air Intercooled
Displacement	3 litre (2998cc)
Bore	95.8mm
Stroke	104mm
Power (DIN)	110kW @ 2840~3500 rpm
Torque (DIN)	370Nm @ 1350~2840 rpm
Maximum Engine Speed	4100 rpm
Compression Ratio	17.5:1
Cooling System / Oil Cooler	Water cooled, 13.7L capacity/ Plate type engine oil cooler
Air Cleaner	Paper Element Type with Restrictor Indicator. Vertical Intake Mounted on Clean Air Side (RH)
Emission Control	Diesel Particulate Filter (DPF) Exhaust Dash Display DPF Status 0~9 (Empty~Full) Parked Regeneration possible from 7~9
Emission Level	ADR 80/03 - Euro 5

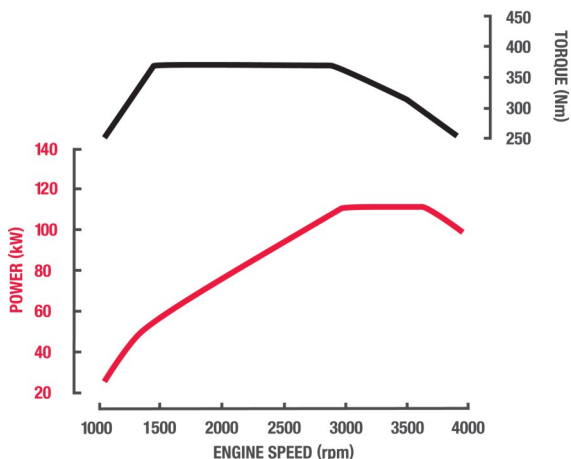

Fuel	
Tank Type	Rectangular Steel Tank with Locking Cap
Fuel Capacity *	100 Litres
Filtration	Filter with Water Separator and Indicator Sensor
Notes	*Max Fill to approx 95% of capacity

Cooling	
Fan Drive	Thermo modulated continuous control (Viscous)
Radiator	Corrugated Fin with Expansion Tank

Electrical	
Voltage	12V Negative Earth
Battery Capacity	2x12V, 70Ah/5hr
Battery Specification	115D31L x2
Headlamp Type	Halogen
Headlamp Capacity	2x55W/60W
Body Builder Harness	Yes*
Notes	*Standard from October 2021 build

Clutch	
Clutch Model	FUSO C4W30
Type	Single Dry Plate, Direct Hydraulic Type

Transmission	
Version	FUSO M038S5
Type/Speeds	5 Speed with In-Dash Gearshift Lever
Features	Synchromesh 1st-5th
Ratios	1st: 5.494 2nd: 3.038 3rd: 1.592 4th: 1.000 5th: 0.723 Rev. 5.494
PTO Opening	LH Side

4x4 Transfer	
Model	FUSO TF3
No of Speeds	2
Synchromesh	No
Ratio - Low	1.987
Ratio - High	1.090

Front Axle	
Axle Version	FUSO D1H
Type	Full Floating Hypoid with Constant Velocity Universal Joints
Hubs	Free Wheel, Manual Locking Type
Ratio	5.285:1
Notes	*See MAX LOADING for vehicle capacity.

Front Suspension	
Type	Multi-Leaf with Double Acting Shock Absorbers
Size	1150x70mm Leaves

Rear Axle	
Type	Full Floating Hypoid Type Positive Locking Limited Slip Differential (LSD).
Axle Version	FUSO D035H
Ratio	5.285:1
Notes	See MAX LOADING for vehicle capacity.

Rear Suspension	
Type	Steel Suspension
Details	Multi-Leaf with Double Acting Shock Absorbers
Size Main Leaves	1250x70mm

Max Loading	
Front	2800kg
Rear	5760kg
Total	6500kg

Options	
Options	H31: 4495/7995kg GVM/GCM Rating  Q44: Fire Service delete power pack option - without driver & far passenger airbag, central locking or electrical front windows

Steering	
Type	Integral Ball and Nut Type
Steering Column	Tilt/Telescopic Adjustable
Power Assist	Standard

# CANTER SPECIFICATIONS

## MODEL

A	4X4 FG WIDE CAB SWB 5 SP. MAN (FGB71CR6SFBC)
B	4X4 FG WIDE CAB MWB 5 SP. MAN (FGB71ER6SFBC)

## WHEEL BASE

2815mm
3415mm

## GVM (optional)

6,500kg (4,495kg)
6,500kg (4,495kg)

## GCM (optional)

10,000kg (7,995kg)
10,000kg (7,995kg)

### Brakes

Type	Hydraulic Dual Circuit with Front and Rear Drums
Size Front	320mm Diameter x 75mm Width
Size Rear	320mm Diameter x 110mm Width
Features	Auto Slack Adjusters ABS plus EBD (Electronic Brake Distribution) Exhaust Brake Brake Priority System
Park Brake	Transmission Mounted

### Wheels & Tyres

Wheel Type	7 x Disc Rims (Including Spare)
Wheel Size	17.5x6.0-127
Wheel Stud Pattern	6 Stud
Tyre Size All	215/75R17.5 124/123 (tubeless) Off-road Tyres Front and Rear (for Extra Traction)
Spare Tyre Carrier	Provided

### Chassis

Type	Reinforced Tapered Channel with Drop Shape
Size	192x60x6mm
Width	752mm
Tensile Strength	440 MPa with 540 MPa Stiffeners

### Instruments

Gauges	Speedometer with Odometer Tachometer Fuel Level Water Temperature
Colour Information Display	Fuel Consumption DPF Bar Chart from 1~9 Water Temperature Maintenance Reminder System Tripmeters

### Multi-Media Package

Satellite Navigation	GPS navigation specifically designed for commercial vehicle applications, with 3 years of Map updates included.
Colour Display	7 inch LCD with touch screen control
Phone Connectivity	Bluetooth® hands free
Audio Visual Entertainment	Bluetooth® music streaming compatible Digital radio DAB+ (also AM/FM for areas not covered by DAB+) & USB
Camera Compatibility	Reverse camera (Factory Fitted) + 5 additional camera options #
Notes	# Cameras available through spare parts

### Standard Features

Airbag(s)	Dual Air Bags and Seat Belt Pre-Tensioners (Driver & Far Side Passenger)
Cruise Control	No
Hill Start System	Yes
Cab Cooling & Heating	Air Conditioner / Heater / Demister
Accessory Power	12V Accessory Power Outlet / Cigar Lighter
Driving	Fuso Multimedia Unit Keyless Central Locking Electric Windows Cup Holders 2 3 seats
Storage	Dual Overhead Storage Pockets In-Dash Centre Document Storage Door Storage Pockets Dash Storage Tray (1 DIN) Coat Hooks
Cab: External	Front End-Outline Marker Lamps Door Side Impact Beams
Chassis	Reverse Warning Buzzer Factory Reverse Camera with Infrared Display and Audible Pickup (Supply only in Cabin with Cab Chassis)

### Service Intervals

Interval*	30,000km or 12 Months (whichever occurs first)
-----------	--

### Warranty\*

Basic/Powertrain	5 Years or 200,000kms (whichever occurs first)
Cab Perforation/Anti Corrosion	5 Years
Notes	* Please refer to Fuso Owners Warranty Booklet for additional terms and conditions.

### Performance

Turning Circle (kerb to kerb - metres)	A 11.4	B 13.4
Road Speed (km/h) at Max Engine Speed	123	
Engine Speed (rpm) at 100km/hr (top gear)	2957	
Startability at Rated GVM (theoretical)*	51%	
Gradeability at Rated GVM (theoretical)*	74%	
Notes	*This is theoretical performance only. Actual performance may vary under different conditions	

### Mass estimated\*

Front*	A 1740kg	B 1750kg
Rear*	A 820kg	B 845kg
Total*	A 2560kg	B 2595kg
Notes	* Mass (est.) includes oil and water but excludes spare wheel, tools & fuel. Weights provided are subject to 3.5% variation (+/-)	

### Dimensions mm

WFF (Width Front Fender) (mm)	1995
WRA (Width Rear Axle) (mm)	2030
WRT (Width Rear Track) (mm)	1560
Width Frame (mm)	750
A - Length Overall (mm)	A 5190 B 5935
C - Front Overhang (mm)	1125
D - Wheelbase (mm)	A 2815 B 3415
G - Front Axle to Rear of Cab (mm)	540
H - Rear of Cab to Rearmost Item Behind Cab (mm)	81
I - Rearmost Item Behind Cab to Rear Axle (mm)	A 2194 B 2794
J - Frame, Rear Axle to End (mm)	A 1195 B 1395
O - Air Intake to Cab Roof (mm)	184
P - Height Cab to Ground (mm)	2475
Q - Height Cab to Frame (mm)	1504
R - Height Rear Frame to Ground (mm)	881

# CANTER SPECIFICATIONS

MODEL	WHEEL BASE	GVM (optional)	GCM (optional)
A 4X4 FG WIDE CAB SWB 5 SP. MAN (FGB71CR6SFBC)	2815mm	6,500kg (4,495kg)	10,000kg (7,995kg)
B 4X4 FG WIDE CAB MWB 5 SP. MAN (FGB71ER6SFBC)	3415mm	6,500kg (4,495kg)	10,000kg (7,995kg)

## Body Builder's Notes

Notes

Chassis reinforcement must be utilised for Tipper/ Demountable type body configurations.

To conform with ADR 13/00 and 14/02 (lighting/mirror requirements) the following must be adhered to at body installation.

- If overall width exceeds 2.1 metres and other than flat type or tipper body is fitted, rear end-outline markers must be installed.
- If overall length exceeds 6.0 metres, side reflectors must be installed.
- If overall length exceeds 7.5 metres and width exceeds 2.1 metres, side marker lamps must be installed.
- If overall width is less than 2.2 metres, the mirrors must be modified to project not more than 230mm.

To conform with ADR 42/04 (General Safety), rear wheel guards must be fitted to the vehicle.



Call 1800 033 557

or visit [fuso.com.au](http://fuso.com.au)

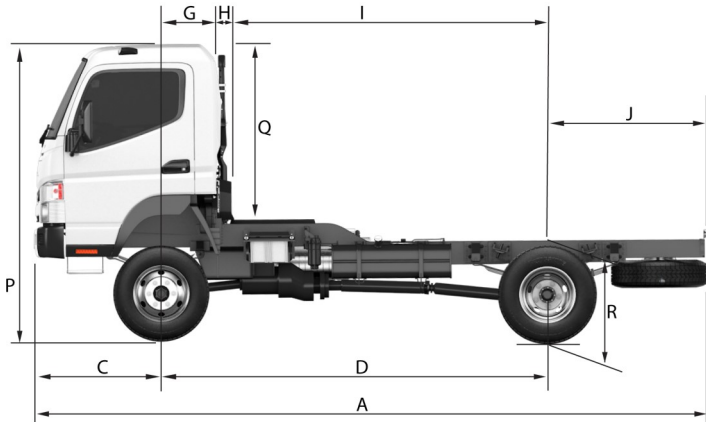
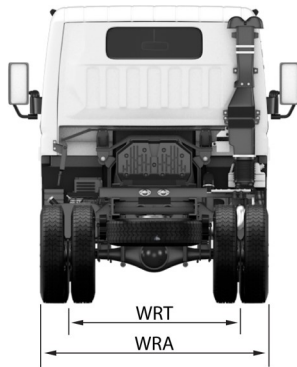

Unless specified in writing herein the accessories, applications, bodies or equipment depicted in this are for illustration purposes only and may not be available from Daimler Truck Australia Pacific Pty Ltd. ABN 86 618 413 282 DTAuP. No representation or warranty whatsoever is given in relation to any accessories, applications, bodies or equipment or suitability of same that are shown herein that may be manufactured, supplied or fitted by a party other than DTAuP. DTAuP reserves the right without notice or obligation to discontinue or make changes to the colour, designs, materials and specifications of the products and options referred to herein at any time. For the most current information and in order to ascertain which accessories, applications, bodies and equipment are available from DTAuP please contact your authorised FUSO dealer. Fuso is a registered trademark of Daimler Truck Australia Pacific Pty Ltd. Copyright DTAuP. Reproduction in whole or part prohibited without written approval. Part Number TSC190E-SSV2. Valid from 05-Nov-21.