

CANTER

FUSO

CANTER 615

4X2 / WIDE CAB / MANUAL OR DUONIC DCT



**OUR SAFEST CANTER EVER WITH AEB, LDWS AND ESP STANDARD.
CLASS LEADING 30,000KM SERVICE INTERVALS.**

GVM

6,000_{KG}

GCM

9,500_{KG}

Power/Torque

110_{kW} / 370_{Nm}

- Light rigid licence required. Can be derated and driven with a passenger car licence.
- Actual product may vary from image shown.

CANTER SPECIFICATIONS

MODEL

A	4X2 615 WIDE CAB MWB 6 SP. AMT (FEB51ER3SFBG)
B	4X2 615 WIDE CAB LWB 6 SP. AMT (FEB51GR3SFBG)
C	4X2 615 WIDE CAB MWB 5 SP. MAN (FEB51ER4SFBG)
D	4X2 615 WIDE CAB LWB 5 SP. MAN (FEB51GR4SFBG)

WHEEL BASE

3400mm
3850mm
3400mm
3850mm

GVM (optional)

6,000kg (4,495kg)
6,000kg (4,495kg)
6,000kg (4,495kg)
6,000kg (4,495kg)

GCM (optional)

9,500kg (7,995kg)
9,500kg (7,995kg)
9,500kg (7,995kg)
9,500kg (7,995kg)

Engine	
Engine Version	FUSO 4P10-T4 Diesel
Configuration	4 Cyl. In-line DOHC, 4-Valve
Injection System	Bosch Common Rail Direct Injection Bosch Piezo Technology Injectors
Type	Variable Geometry Turbo Charged Air to Air Intercooled
Displacement	3 litre (2998cc)
Bore	95.8mm
Stroke	104mm
Power (DIN)	110kW @ 2840~3500 rpm
Torque (DIN)	370Nm @ 1350~2840 rpm
Maximum Engine Speed	4100 rpm
Compression Ratio	17.5:1
Cooling System / Oil Cooler	Water cooled, 13.7L capacity/ Plate type engine oil cooler
Air Cleaner	Paper Element Type with Restrictor Indicator. Vertical Intake Mounted on Clean Air Side (RH)
Emission Control	Diesel Particulate Filter (DPF) Exhaust Dash Display DPF Status 0~9 (Empty~Full) Parked Regeneration possible from 7~9
Emission Level	ADR 80/03 - Euro 5

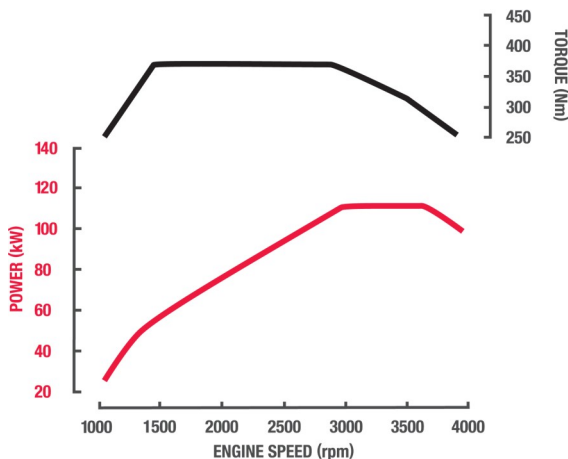

Fuel	
Tank Type	Rectangular Steel Tank with Locking Cap
Fuel Capacity *	100 Litres
Filtration	Filter with Water Separator and Indicator Sensor
Notes	*Max Fill to approx 95% of capacity

Cooling	
Fan Drive	Thermo modulated continuous control (Viscous)
Radiator	Corrugated Fin with Expansion Tank

Electrical	
Voltage	12V Negative Earth
Battery Capacity	2x12V, 70Ah/5hr
Battery Specification	115D31L x2
Headlamp Type	LED
Body Builder Harness	Yes

Clutch		
Clutch Model	A B Fully Automated Dual Clutch (no clutch pedal)	C D FUSO C4W30
Type	A B Dual Clutch (Wet Multi-plate)	C D Single Dry Plate, Direct Hydraulic Type

Transmission		
Version	A B FUSO DUONIC M038S6	C D FUSO M038S5
Type/Speeds	A B 6 Speed Dual Clutch with Auto and Manual Modes	C D 5 Speed with In-Dash Gearshift Lever
Features	A B Virtually Instant Gear Changes In-Dash Gear Lever with Park Brake Position ECO Mode to Minimise Fuel Usage	C D Synchromesh 1st-5th
Ratios	A B 1st: 5.397 2nd: 3.788 3rd: 2.310 4th: 1.474 5th: 1.000 6th: 0.701 Rev. 5.397	C D 1st: 5.494 2nd: 3.038 3rd: 1.592 4th: 1.000 5th: 0.723 Rev. 5.494
PTO Opening	LH Side	

Front Axle	
Axle Version	FUSO F200T
Type	Reverse Elliot 'I' Beam
Capacity *	2600kg
Notes	*See MAX LOADING for vehicle capacity.

Front Suspension	
Type	Multi-Leaf with Stabiliser Bar and Double Acting Shock Absorbers
Size	1150x70mm Leaves

Rear Axle		
Type	Full Floating Banjo Type	
Axle Version	A B FUSO R033T	C D FUSO R030T
Capacity*	4500kg	
Ratio	4.875:1	
Notes	*See MAX LOADING for vehicle capacity.	

Rear Suspension	
Type	Steel Suspension
Details	Semi-Elliptic Leaf with Stabiliser Bar and Double Acting Shock Absorbers
Size Main Leaves	1250x70mm

Max Loading	
Front	2570kg
Rear	4500kg
Total	6000kg

Options	
Options	H31: 4495/7995kg GVM/GCM Rating

Steering	
Type	Integral Ball and Nut Type
Steering Column	Tilt/Telescopic Adjustable
Power Assist	Standard



CANTER SPECIFICATIONS

MODEL	WHEEL BASE	GVM (optional)	GCM (optional)
A 4X2 615 WIDE CAB MWB 6 SP. AMT (FEB51ER3SFBG)	3400mm	6,000kg (4,495kg)	9,500kg (7,995kg)
B 4X2 615 WIDE CAB LWB 6 SP. AMT (FEB51GR3SFBG)	3850mm	6,000kg (4,495kg)	9,500kg (7,995kg)
C 4X2 615 WIDE CAB MWB 5 SP. MAN (FEB51ER4SFBG)	3400mm	6,000kg (4,495kg)	9,500kg (7,995kg)
D 4X2 615 WIDE CAB LWB 5 SP. MAN (FEB51GR4SFBG)	3850mm	6,000kg (4,495kg)	9,500kg (7,995kg)

Brakes

Type	Hydraulic Dual Circuit with Front and Rear Discs Twin Calliper Front and Rear
Size Front	235x40mm
Size Rear	235x40mm
Features	ABS plus EBD (Electronic Brake Distribution) Active Emergency Braking System (AEBS) Electronic Stability Program (ESP) Exhaust Brake Electronic Brake Wear Sensors
Park Brake	Transmission Mounted

Wheels & Tyres

Wheel Type	7 x Single Piece Disc Rims (Including Spare)
Wheel Size	16.0x5.5K-115
Wheel Stud Pattern	5 Stud 208 PCD
Tyre Size All	205/85R16 117/115
Spare Tyre Carrier	Provided

Chassis

Type	Reinforced Tapered Channel
Size	192x60x6mm
Width	752mm
Tensile Strength	440 MPa

Instruments

Gauges	Speedometer with Odometer Tachometer Fuel Level Water Temperature
Colour Information Display	Fuel Consumption DPF Bar Chart from 1~9 Water Temperature Lane Departure Warning Maintenance Reminder System Tripmeters

Multi-Media Package

Satellite Navigation	GPS navigation specifically designed for commercial vehicle applications, with 3 years of Map updates included.
Colour Display	8 inch LCD with touch screen control
Phone Connectivity	Bluetooth® hands free + phone mirroring.
Audio Visual Entertainment	Bluetooth® music streaming compatible Digital radio DAB+ (also AM/FM for areas not covered by DAB+) & USB
Reversing Camera Compatible	1 Reverse Camera fitted as standard Display can accept up to 5 additional cameras#
Notes	# Cameras available through spare parts

Standard Features

Airbag(s)	Dual Air Bags and Seat Belt Pre-Tensioners (Driver & Far Side Passenger)
Active Safety Features	ABS plus Electronic Brake force Distribution (EBD) Advanced Emergency Braking (AEBS) Anti-Slip Regulator (ASR) Electronic Stability Program (ESP) Lane Departure Warning System (LDWS)
Cruise Control	A B C D Yes No
Hill Start System	Yes
Cab Cooling & Heating	Air Conditioner / Heater / Demister
Accessory Power	12V Accessory Power Outlet / Cigar Lighter
Driving	Fuso Multimedia Unit Keyless Central Locking Electric Windows Cup Holders 2 3 seats
Storage	Dual Overhead Storage Pockets In-Dash Centre Document Storage Door Storage Pockets Dash Storage Tray (1 DIN) Coat Hooks
Cab: External	Front End-Outline Marker Lamps Door Side Impact Beams
Chassis	Reverse Warning Buzzer Factory Reverse Camera with Infrared Display and Audible Pickup (Supply only in Cabin with Cab Chassis)

Service Intervals

Interval*	30,000km or 12 Months (whichever occurs first)
-----------	--

Warranty

Basic/Powertrain	5 Years or 200,000kms (whichever occurs first)
Cab Perforation/Anti Corrosion	5 Years
Notes	* based on normal operating conditions and may be reduced when operating under severe conditions.

Performance

Turning Circle (kerb to kerb - metres)	A C B D 11.6 13.0
Road Speed (km/h) at Max Engine Speed	133
Engine Speed (rpm) at 100km/hr (top gear)	A B C D 2478 2555
Gradeability at Rated GVM (theoretical)*	A B C D 34% 35%
Notes	*This is theoretical performance only. Actual performance may vary under different conditions

Mass estimated*

Front*	A B C D 1565kg 1550kg
Rear*	A B C D 705kg 725kg 695kg 715kg
Total*	A B C D 2270kg 2290kg 2245kg 2265kg
Notes	* Mass (est.) includes oil and water but excludes spare wheel, tools & fuel. Weights provided are subject to 3.5% variation (+/-)

CANTER SPECIFICATIONS

MODEL	WHEEL BASE	GVM (optional)	GCM (optional)
A 4X2 615 WIDE CAB MWB 6 SP. AMT (FEB51ER3SFBG)	3400mm	6,000kg (4,495kg)	9,500kg (7,995kg)
B 4X2 615 WIDE CAB LWB 6 SP. AMT (FEB51GR3SFBG)	3850mm	6,000kg (4,495kg)	9,500kg (7,995kg)
C 4X2 615 WIDE CAB MWB 5 SP. MAN (FEB51ER4SFBG)	3400mm	6,000kg (4,495kg)	9,500kg (7,995kg)
D 4X2 615 WIDE CAB LWB 5 SP. MAN (FEB51GR4SFBG)	3850mm	6,000kg (4,495kg)	9,500kg (7,995kg)

Dimensions mm			
WFF (Width Front Fender) (mm)	1995		
WRA (Width Rear Axle) (mm)	1936		
WRT (Width Rear Track) (mm)	1495		
Width Frame (mm)	752		
A - Length Overall (mm)	A C	B D	
	5935	6685	
C - Front Overhang (mm)	1140		
D - Wheelbase (mm)	A C	B D	
	3400	3850	
G - Front Axle to Rear of Cab (mm)	525		
H - Rear of Cab to Rearmost Item Behind Cab (mm)	A B	C D	
	50	81	
I - Rearmost Item Behind Cab to Rear Axle (mm)	A	B	C
	2825	3275	2794
J - Frame, Rear Axle to End (mm)	A C	B D	
	1395	1695	
P - Height Cab to Ground (mm)	2180		
Q - Height Cab to Frame (mm)	1514		
R - Height Rear Frame to Ground (mm)	A C	B D	
	783	782	

Body Builder's Notes

Notes

Chassis reinforcement must be utilised for Tipper/ Demountable type body configurations. To conform with ADR 13/00 and 14/02 (lighting/mirror requirements) the following must be adhered to at body installation.

- If overall width exceeds 2.1 metres and other than flat type or tipper body is fitted, rear end-outline markers must be installed.
- If overall length exceeds 6.0 metres, side reflectors must be installed.
- If overall length exceeds 7.5 metres and width exceeds 2.1 metres, side marker lamps must be installed.
- If overall width is less than 2.2 metres, the mirrors must be modified to project not more than 230mm. To conform with ADR 42/04 (General Safety), rear wheel guards must be fitted to the vehicle.

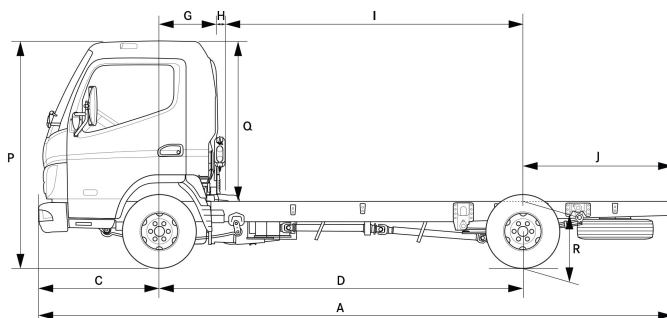
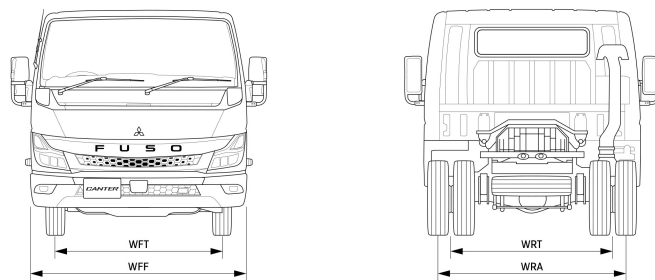

Call 1800 033 557

or visit fuso.com.au

Unless specified in writing herein the accessories, applications, bodies or equipment depicted in this are for illustration purposes only and may not be available from Daimler Truck Australia Pacific Pty Ltd. ABN 86 618 413 282 DTAuP. No representation or warranty whatsoever is given in relation to any accessories, applications, bodies or equipment or suitability of same that are shown herein that may be manufactured, supplied or fitted by a party other than DTAuP. DTAuP reserves the right without notice or obligation to discontinue or make changes to the colour, designs, materials and specifications of the products and options referred to herein at any time. For the most current information and in order to ascertain which accessories, applications, bodies and equipment are available from DTAuP please contact your authorised FUSO dealer. Fuso is a registered trademark of Daimler Truck Australia Pacific Pty Ltd. Copyright DTAuP. Reproduction in whole or part prohibited without written approval. Valid from 19-Mar-24.